

NIPPLE BRANCHETTE®



SIZE : 1/2 - 4 **IDENTIFICATION :** X-STG, SCH.160, AND XX-STG
MATERIAL : ALL ASTM / ASME MATERIAL GRADES
PRODUCT CONFORMITY : MSS SP-97, ASME B1.20.1 (NPT) B31.1, B31.3

THE NIPPLE BRANCHETTE IS AVAILABLE WITH PLAIN END, THREADED END, BEVELED END, OR GROOVED END IN ALL GRADES OF MATERIALS. STANDARD HEIGHTS ARE 3-1/2", 4-1/2", 5-1/2", AND 6-1/2" AND ARE AVAILABLE IN ALL END CONDITIONS. OTHER HEIGHTS ARE AVAILABLE UPON REQUEST. THREADED ENDS HAVE MALE NPT THREADS IN ACCORDANCE WITH ASME B1.20.1. BEVELED ENDS ARE IN ACCORDANCE WITH ASME B16.25. NIPPLE BRANCHETTES MEET THE REQUIREMENTS OF ASME B31.3 FOR INTEGRALLY REINFORCED BRANCH CONNECTIONS.

ELIMINATE

- 2-PIECE CONSTRUCTION
- 1 MATERIAL TEST REPORTS
- 1 WELDS - 1 NDT INSPECTIONS (WHEN REQUIRED)
- COSTLY FIT UP AND FABRICATION TIME
- WELD PROTRUSION IN BORE AT WELD POINTS

ADVANTAGES

- 1-PIECE CONSTRUCTION
- 1 MATERIAL TEST REPORT
- 1 WELD - 1 NDT INSPECTION (WHEN REQUIRED)
- REDUCED FIT UP AND FABRICATION TIME
- SMOOTH SEAMLESS BORE PROVIDES BETTER FLOW

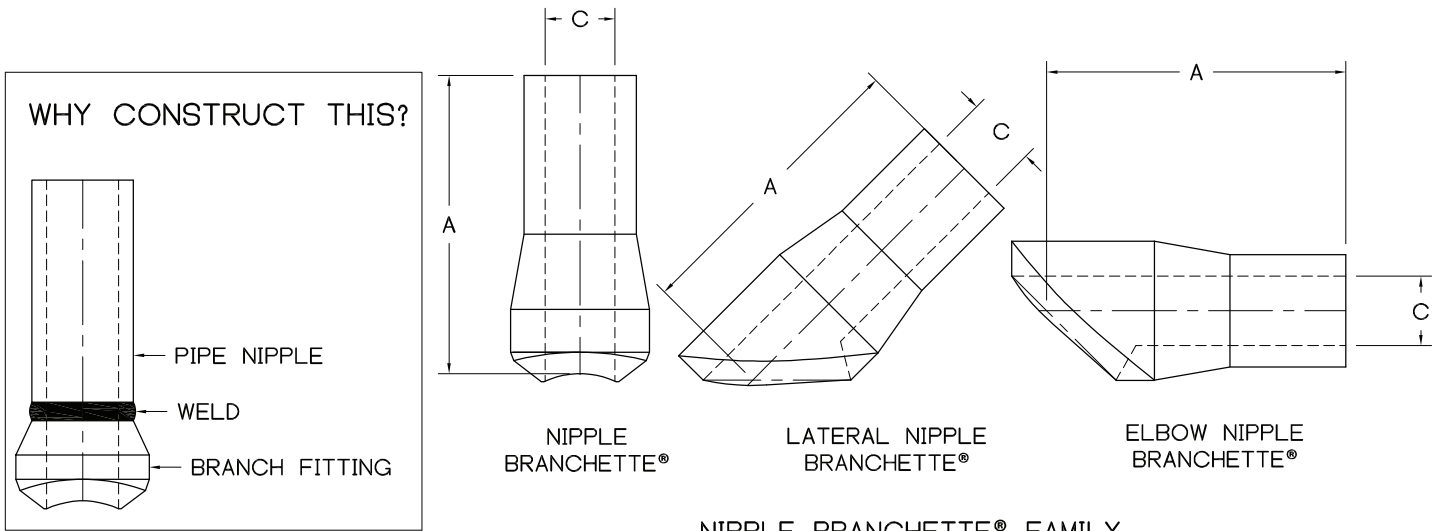

NIPPLE BRANCHETTE® FAMILY

DIMENSIONS AND WEIGHTS										
NPS	STANDARD HEIGHTS "A"				BORE "C"			WT 90° FITTING 3 1/2 LG		
	3 1/2	4 1/2	5 1/2	6 1/2	X-STG	SCH.160	XX-STG	XSTG	SCH.160	XX-STG
1/2	3 1/2	4 1/2	5 1/2	6 1/2	0.546	0.464	0.252	0.68	0.73	0.83
3/4	3 1/2	4 1/2	5 1/2	6 1/2	0.742	0.612	0.434	0.77	0.89	1.01
1	3 1/2	4 1/2	5 1/2	6 1/2	0.957	0.815	0.599	0.85	1.03	1.23
1 1/4	3 1/2	4 1/2	5 1/2	6 1/2	1.278	1.160	0.896	1.63	1.82	2.16
1 1/2	3 1/2	4 1/2	5 1/2	6 1/2	1.500	1.338	1.100	1.92	2.22	2.58
2	3 1/2	4 1/2	5 1/2	6 1/2	1.939	1.687	1.503	2.44	3.04	3.40

NOTES: SPECIAL DIMENSIONS AVAILABLE BY REQUEST