

SOCKET WELD LATERAL BRANCHETTE®

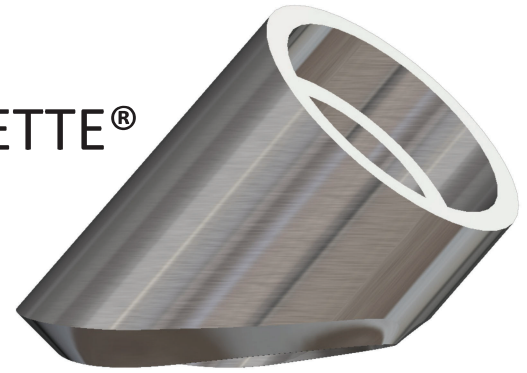

SIZE : 1/4 - 2 **IDENTIFICATION :** 3000, 6000, 9000

MATERIAL : ALL ASTM / ASME MATERIAL GRADES

PRODUCT CONFORMITY : MSS SP-97, ASME B16.11, ASME B31.1, ASME B31.3

LONGITUDINAL SECTION

TRANSVERSE SECTION

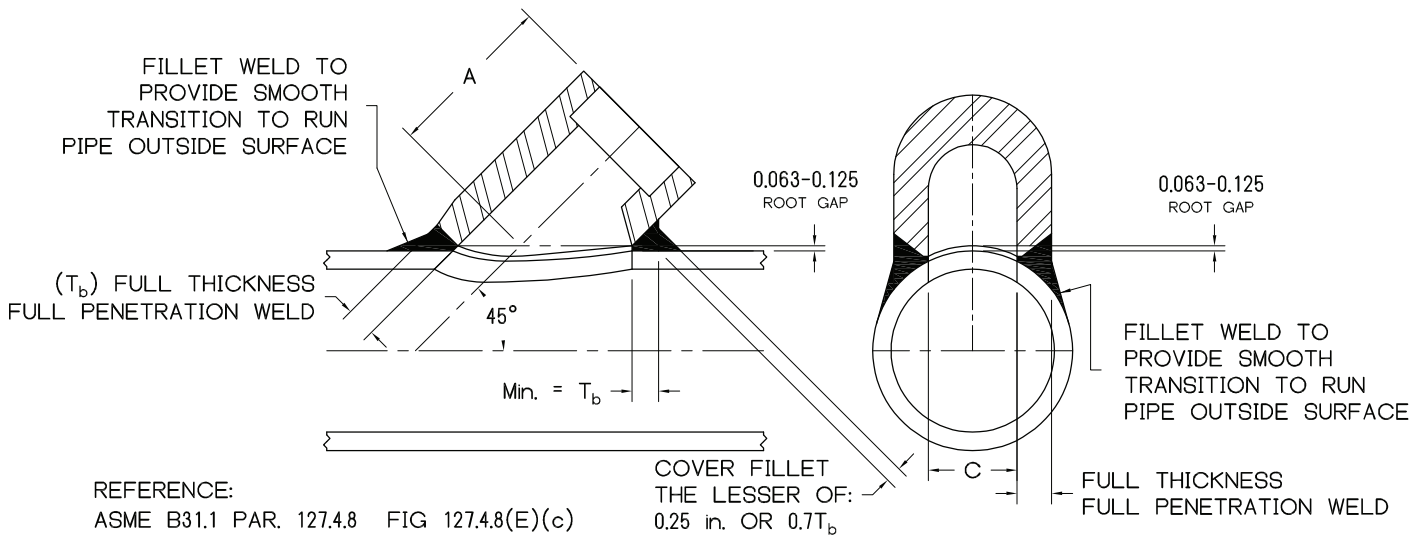

DIMENSIONS AND CONSOLIDATIONS

NPS	SOCKET DEPTH	CL.3000 (3M)			CL.6000 (6M)			CL.9000 (9M)		
		RUN PIPE CORRELATION: X-STG			RUN PIPE CORRELATION: SCH.160			RUN PIPE CORRELATION: XX-STG		
		A	C	CONSOLIDATION	A	C	CONSOLIDATION	A	C	CONSOLIDATION
1/4	0.375	1 9/16	0.364	36 - 1/4						
3/8	0.375	1 9/16	0.493	36 - 3/8						
1/2	0.375	1 9/16	0.622	1/2 36 - 3/4	1 7/8	0.464	36 - 1/2	1 7/8	0.252	36 - 1/2
3/4	0.375	1 7/8	0.824	1 - 3/4 36 - 1 1/4	2 3/16	0.612	36 - 3/4	2 3/16	0.434	36 - 3/4
1	0.500	2 3/16	1.049	1 1 1/2 - 1 1/4 36 - 2	2 1/2	0.815	1 36 - 1 1/4	2 1/2	0.599	36 - 1
1 1/4	0.500	2 1/2	1.380	1 1/2 - 1 1/4 3 - 2 36 - 3 1/2	2 5/8	1.160	2 - 1 1/4 36 - 2 1/2	2 5/8	0.896	1 1/4 36 - 1 1/2
1 1/2	0.500	2 9/16	1.610	2 - 1 1/2 4 - 2 1/2 36 - 5	3 1/8	1.338	1 1/2 3 - 2 36 - 3 1/2	3 1/8	1.100	2 - 1 1/2 36 - 2 1/2
2	0.625	3 1/16	2.067	2 2 1/2 3 1/2 - 3 6 - 4 36 - 8	3 1/8	1.687	2 1/2 - 2 5 - 3 36 - 6	3 1/8	1.503	2 4 - 2 1/2 36 - 5

NOTES : 1. LARGER SIZES AND SPECIAL DIMENSIONS AVAILABLE

2. T_b AVAILABLE UPON REQUEST

2. TYPICAL SOCKET DEPTH TOLERANCE: +.063 / - .000